

OPTION  
REAR AIR INTAKE  
ONLY WITH EC Radial Fan

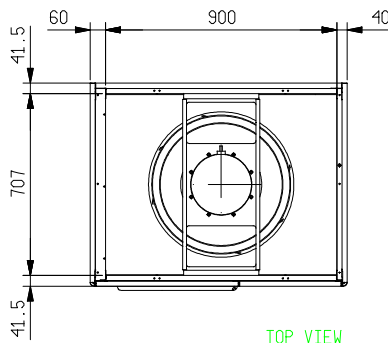

EC Radial Fan

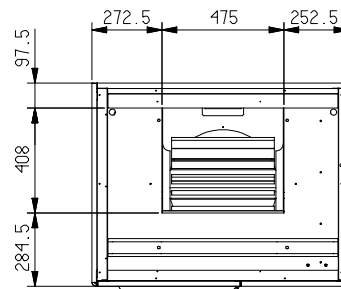

Centrifugal Fan

TOP VIEW

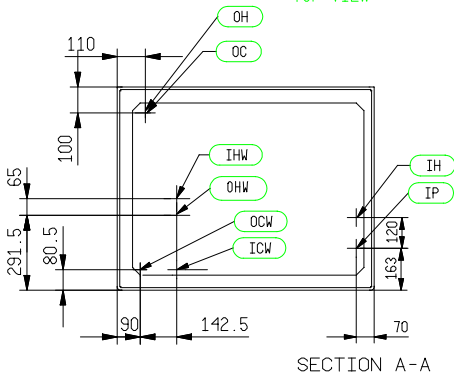

REAR/BOTTOM SUCTION  
VERSION

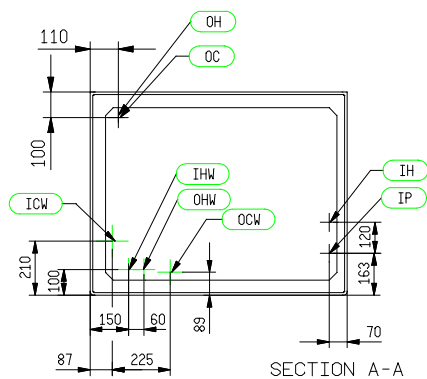

FRONTAL SUCTION  
VERSION

ITALIANO	ENGLISH
ICW: IN acqua refrigerata AC	ICW: IN chilled water AC
OCW: OUT acqua refrigerata AC	OCW: OUT chilled water AC
IP: IN alimentazione elettrica	IP: IN power supply
IH: IN umidificatore	IH: IN humidifier water
OH: OUT umidificatore	OH: OUT humidifier water
IHW: IN acqua calda	IHW: IN hot water
OHW: OUT acqua calda	OHW: OUT hot water
OC: OUT scarico condensa	OC: OUT condensate water drain

Version : AC  
Model : 25 - 30  
Air flow configuration : OVER

